

Marshall

**Jim Marshall (Products) Limited,
Denbigh Road, Bletchley,
Milton Keynes,
MK1 1DQ,
ENGLAND.**

TEL: (0908) 375411 FAX: (0908) 376118

Whilst the information contained herein is correct at the time of publication; due to our constant improvement and development, Jim Marshall (Products) Limited reserve the right to alter specifications without prior notice.

M0024/91/10

Marshall

PEDALS HANDBOOK

SHRED MASTER

DRIVE MASTER

BLUES BREAKER®

INTRODUCTION

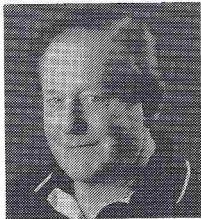

Congratulations!

I would like to personally thank you for selecting one of our range of effects pedals.

For over 30 years the name Marshall has been synonymous with the greatest sounds in rock music. We work hand in hand with guitarists throughout the world to maintain and improve that special unique ingredient, "The Marshall Sound".

These three latest creations, each with its own distinct personality, cover the full spectrum of sounds that have evolved around the original sound of Marshall amplifiers. They can be used alone or in combination to create your own Marshall sound!

As with all of our products, the utmost attention has been paid to the quality of materials and manufacture in order to provide you with the best possible reliability and tone.

Please be sure to read this handbook carefully before operating your pedal and above all, enjoy the use of your Marshall unit to the full.

Thank you sincerely

Jim Marshall

SHRED MASTER

Marshall were the originators of the sound of rock and are the masters of guitar sound dynamics.

The Shred Master pedal contains the most extreme gain levels yet produced. From smooth lead and crunch, through hard rock and power rhythm, to all out thrash and death metal, this pedal has it all.

CONTROLS

① GAIN:- This controls the intensity of the drive and will provide a stunning range of overdrive selections. Lower settings give sustained lead and potent crunch rhythm tones. As the gain increases, the sound gets wilder with massive sustain even at low volume levels. Full gain settings are not for the faint hearted!

② BASS:- Controls the lower frequencies giving a range from thudding heavy rhythm, to tight and punchy solo response.

③ CONTOUR:- This control provides the key to an unbelievable range of distortion tones. When backed off, the

sound is smooth and fat for more lyrical blues/rock playing styles. Increasing the contour changes the character of the mid response and enhances the treble and bass frequencies. The effect is devastating, with high contour selections delivering a barrage of thrash metal tones.

④ TREBLE:- High end response control which tailors the attack and enhances the harmonic content.

⑤ VOLUME:- Provides control of the overall level and amount of boost.

⑥ SWITCH:- On/off switch to bypass or activate the pedal with indicator to show status.

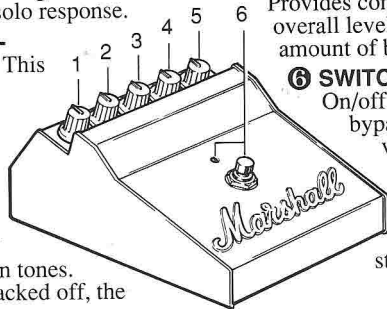

DRIVE MASTER

The original Guv'nor was the first modern Marshall overdrive pedal and proved incredibly popular throughout the world. The Drive Master takes things a stage further, with a new tone and drive network to push performance levels even higher. Where most pedals give at best just two tone controls, the Drive Master's three band tone network acts as if adding an extra amp to your set up, with real Marshall tone and overdrive.

CONTROLS

① GAIN:- This control provides the amount of drive and distortion. Lower settings are ideal for crunch and blues, with the intensity increasing to a rich full metal tone as the gain is advanced.

② / ④ BASS, MIDDLE & TREBLE:- Three band EQ network which combines to give the fullest selection of guitar tones. The Middle control is particularly effective for "fattening" or "hollowing" the sound to suit the playing style.

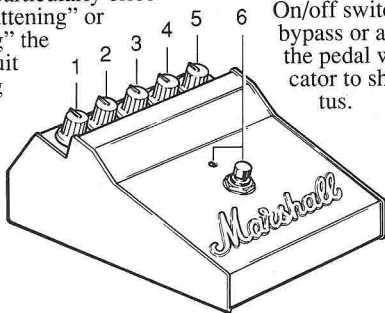

Experimentation with the extremes of all the controls will provide your optimum settings.

⑤ VOLUME:- Level control for the overall output of the Drive Master. Due to the high output levels giving dramatic volume boost, care should be taken in setting the level balance of the signal with and without the Drive Master switched in.

⑥ SWITCH:- On/off switch to bypass or activate the pedal with indicator to show status.

BLUES BREAKER

The sound of the original Marshall BLUESBREAKER amplifier began a legend, with the smooth tone, rich warmth and full character that gave guitarists more expression than ever before.

Your Bluesbreaker pedal captures the magic of those classic vintage amps and will add sweetness and raunch to your guitar sound, but with extra edge to carry solos and squeeze out those vital harmonics. The Bluesbreaker is highly sensitive to the touch of the player and can be as subtle or dramatic as you make it.

CONTROLS

① GAIN:- Sweeps through a range of sounds from subtly distorted with extra edge on lower settings, to all out vintage "balls" on high settings.

② TONE:- Wide ranging control giving lively bite and attack on higher settings. The tone smoothes as the control is backed off, with an increase in the lows and mids for rich creamy sounds at the lower end.

③ VOLUME:- Overall level control to adjust the volume of the effects signal. The Bluesbreaker gives effective level boost for solos or crunch rhythm and will produce its magic through either a clean or distorted amp channel.

④ SWITCH:- On/off switch to bypass or activate the pedal with indicator to show status.

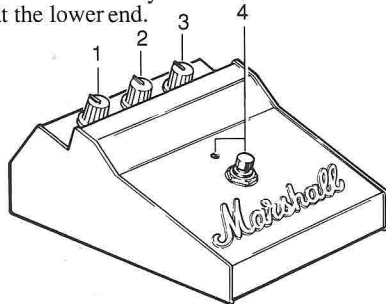

CONNECTIONS

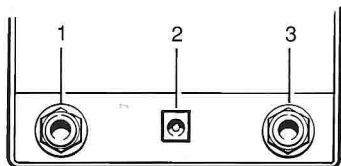

① **INPUT JACK:-** For connection of the cable from the guitar.

② **MAINS ADAPTOR:-** Input for a 9VDC mains adaptor.

③ **OUTPUT JACK:-** For

the connection of the cable from the pedal to the amplifier input socket.

Note: For best results, overdrive pedals should not be connected through the effects loop of your amplifier.

BATTERY REPLACEMENT

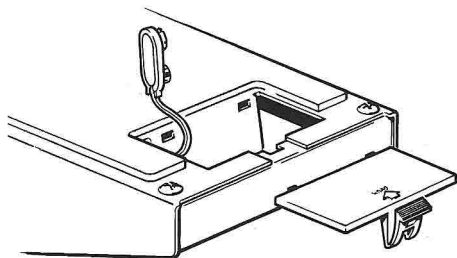

① To replace the battery, remove the cover plate and disconnect the battery connector lead.

② Use PP3 or equivalent battery (for improved battery life use alkaline type)

③ Always ensure that the battery is removed when the pedal is not in use for long periods.

④ Dispose of old battery in a safe place.

BASIC SETTINGS

SHRED MASTER

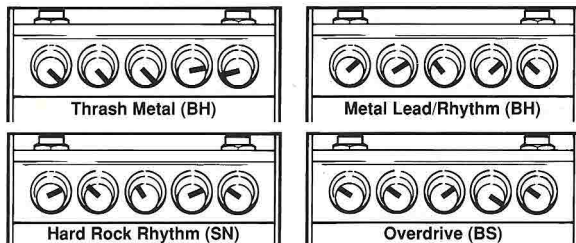

DRIVE MASTER

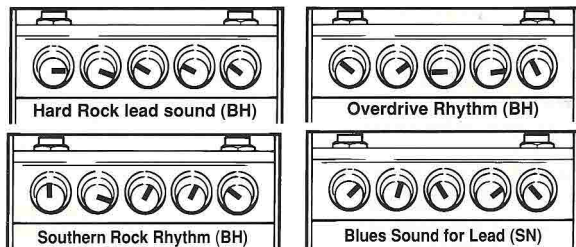

BLUES BREAKER

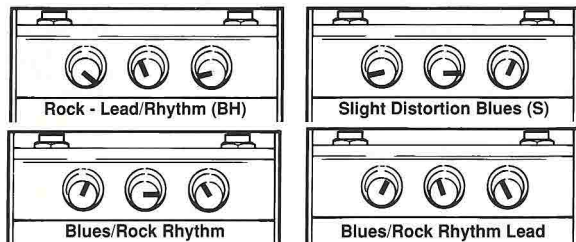

These settings give a guide to the many sounds available from your Marshall pedal. By fine tuning the controls you will find YOUR Marshall sound! (BH) Bridge Humbucking (S) Single coil (SN) Single coil Neck (BS) Bridge Single coil